

IEI Controls

DutyMaster MultiPump Lift Station Controller



Operational Features

- Controls 1 to 4 Pumps
- Lift Station Level
- Lift Station Flow
- High High Level Float Backup Input
- Outside Alarm Light
- Battery Backup UPS
- Level, Flow and Temperature Trending
- Remote Pump Hand Operation
- Remote Pump Disable
- Operator and Engineer Password Protection
- Graphical Touch Screen Local Control HMI
- Dead Front Design
- Pump Motor Overload

Engineering Data

- Rate of Change of Level
- Pump Efficiency
- Pump Energy
- Pump Amps
- Pump Seal Leak Detection
- Pump Temperature Alarm
- Pump Run Time
- Enclosure Temperature
- SCADA Communications with Ethernet MODBUS TCP or Serial MODBUS RTU
- Intrinsically Safe Class 1 Division 1 Wiring
- Remote MultiPump SCADA Software Development

Alarms

- Pump Seal
- Pump Temperature
- AC Power Fail
- Battery Power Fail
- High/Low Level Float
- Pump Excess Run Time
- Temperatures
- Loss of Communications



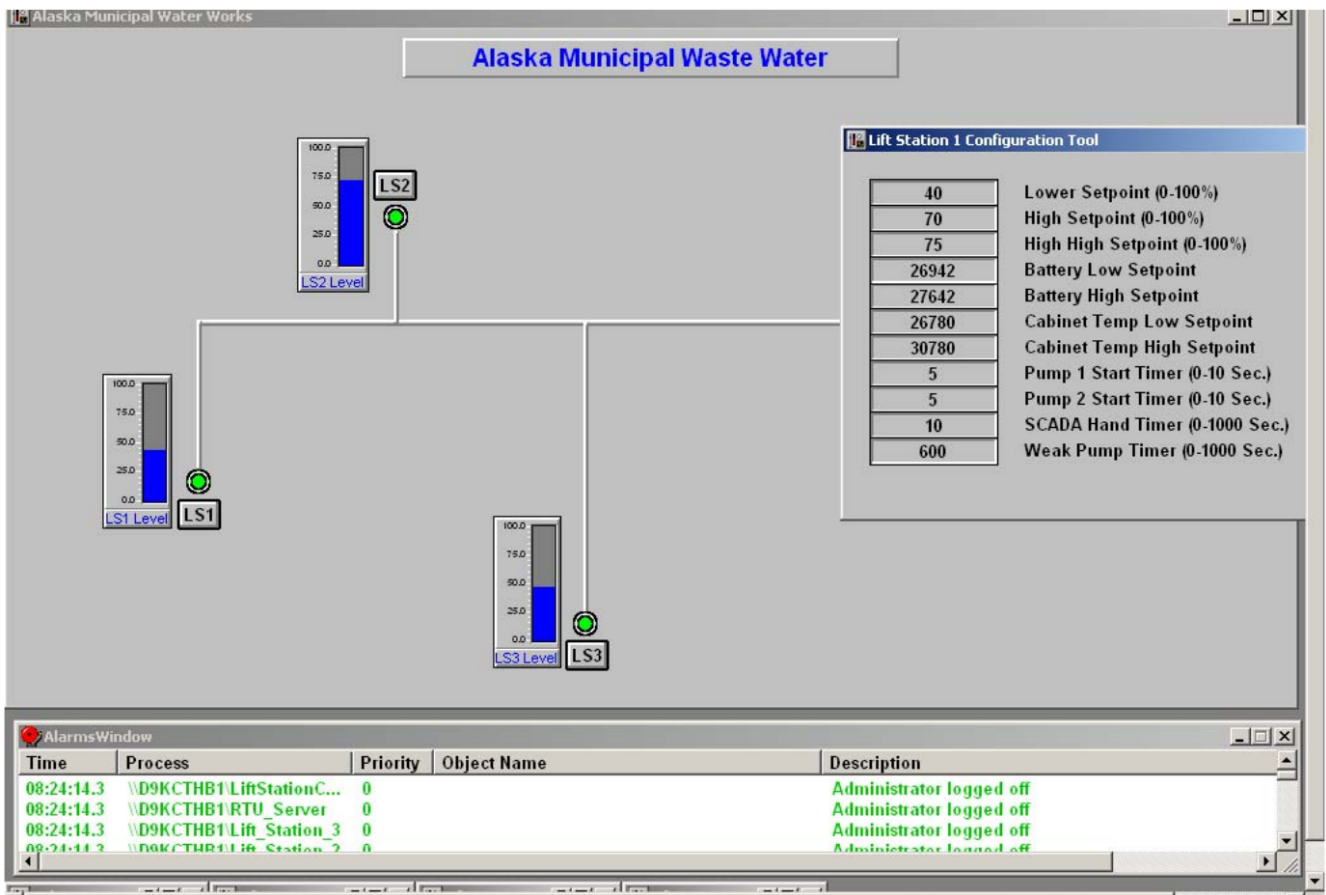

MultiPump SCADA Package

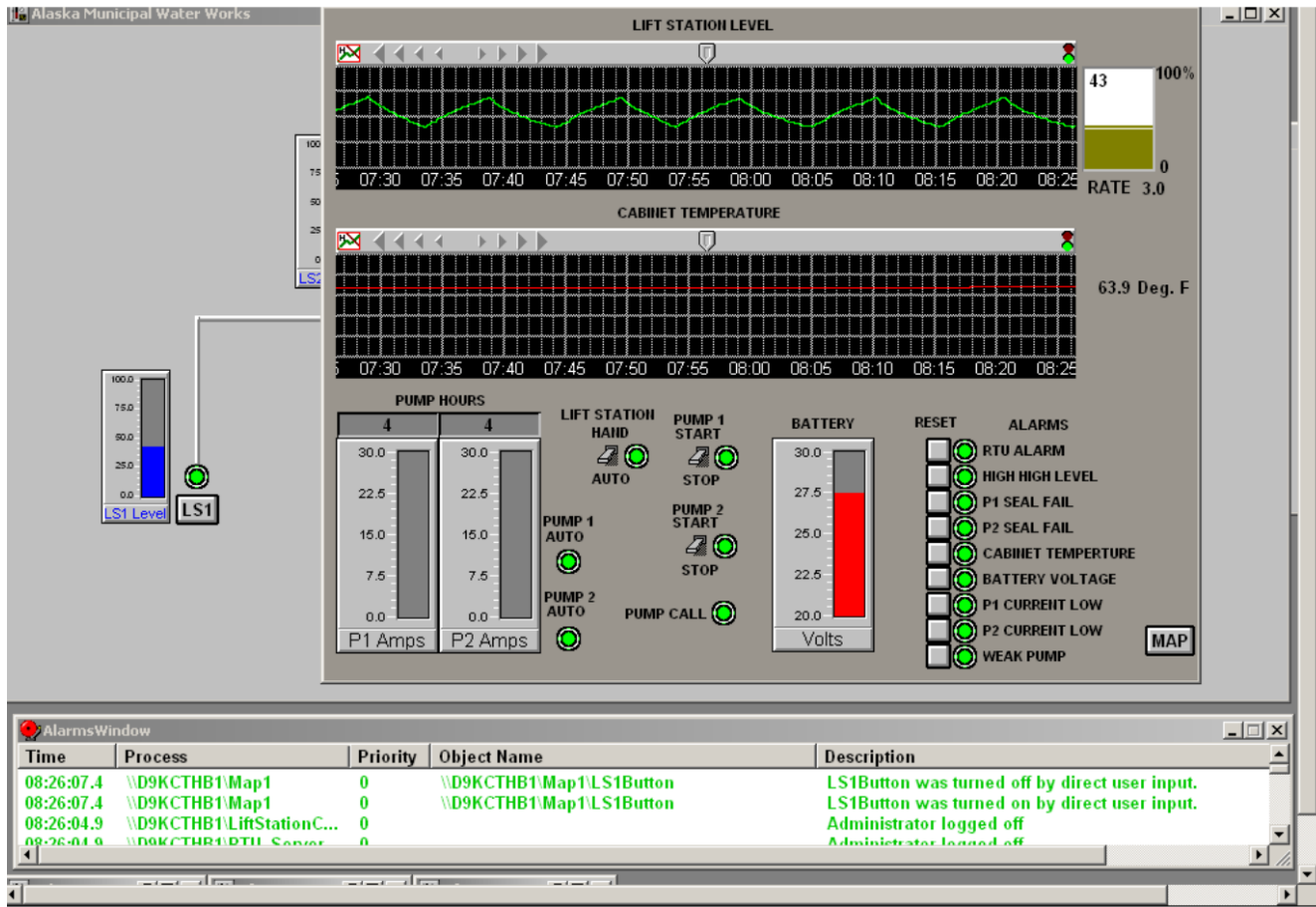

MultiPump SCADA Software

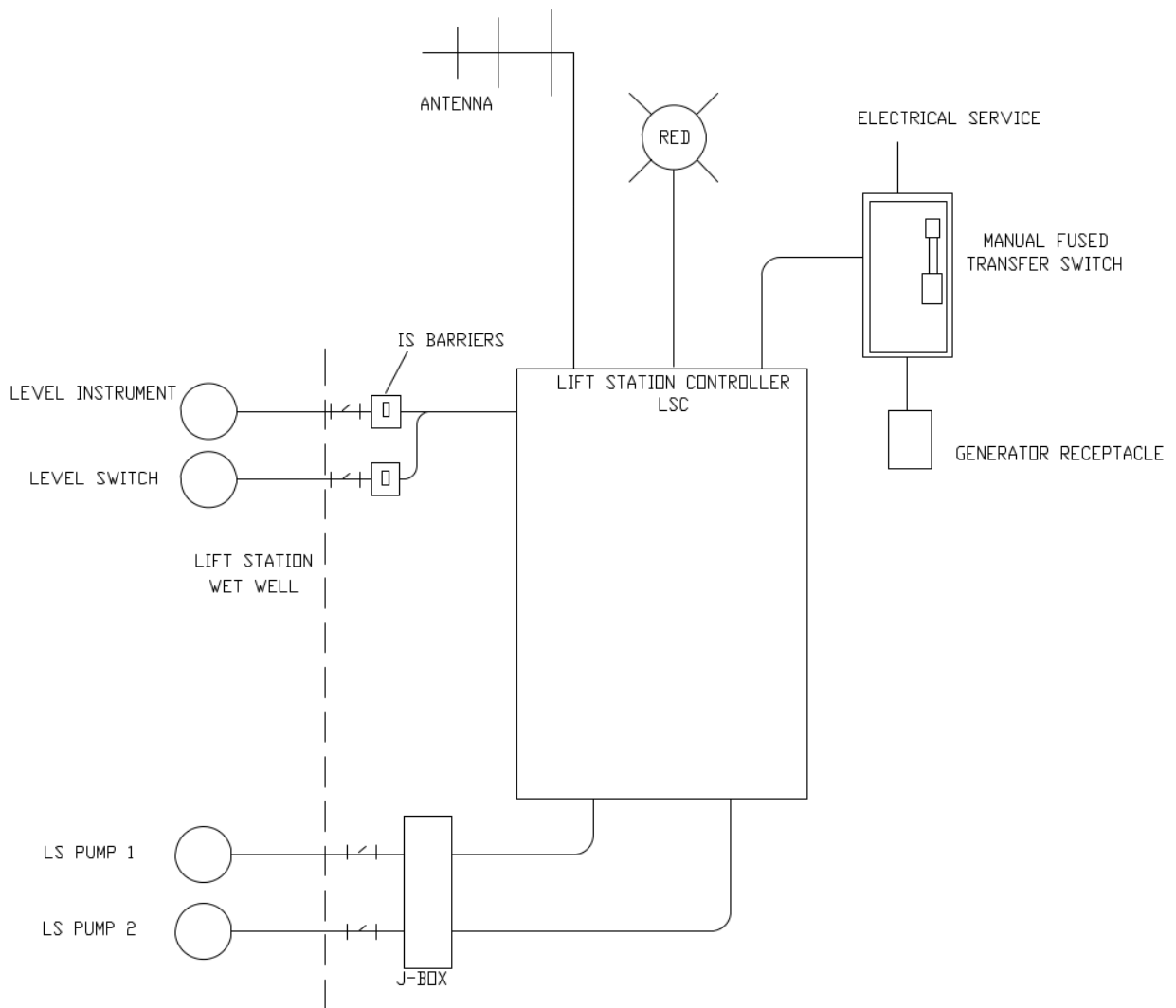

Typical Two Pump Lift Station